

WESTWOOD DESIGN

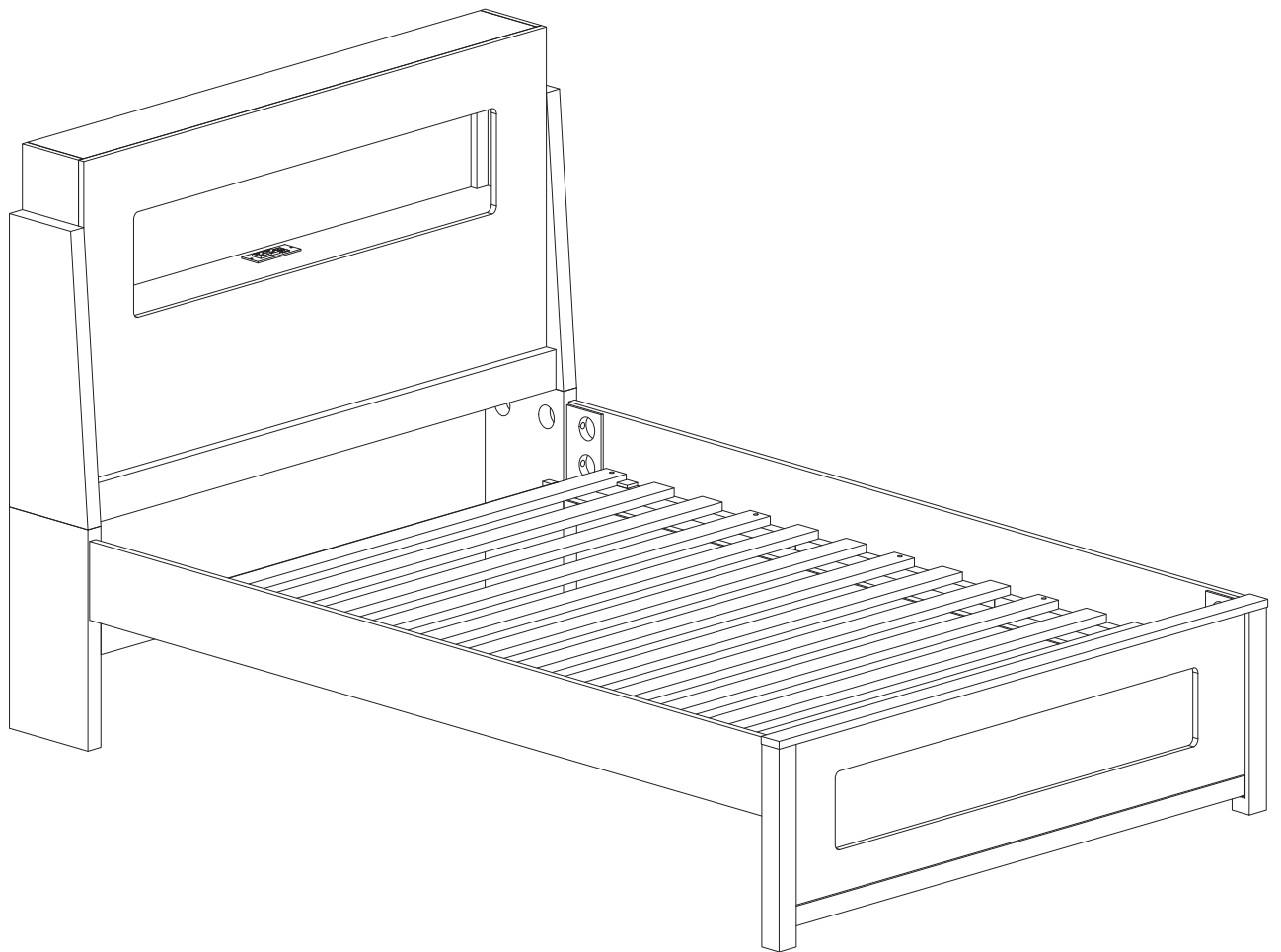

DARBY YOUTH BEDROOM

Twin Bed / Lit complet

Assembly Instruction

Instructions d'assemblage

Congratulations on your purchase of a Westwood product. We take great pride in the quality and design of our furniture. It is important that you read these instructions carefully and completely to ensure that this product functions as it was designed.

After opening the package, check to see that all the parts are present. If you think something is missing, please contact your retailer, and they can arrange to have the missing parts quickly replaced. You can also contact us directly, by calling 1-908-719-4707, or emailing support@westwoodbaby.com

If any aspect of these instructions is unclear, please contact your retailer or Westwood Design for assistance.

Félicitations pour votre achat d'un produit Westwood. Nous sommes très fiers de la qualité et de la conception de nos meubles. Il est important que vous lisiez ces instructions de manière attentive et complète pour vous assurer que ce produit fonctionne tel qu'il a été conçu.

Après l'ouverture de l'emballage, vérifiez que toutes les composantes du produit sont présentes. Si vous pensez qu'un des éléments manque, veuillez communiquer avec votre détaillant et il pourra vous obtenir les pièces manquantes rapidement. Vous pouvez aussi contacter directement Westwood, en téléphonant au 1-908-719-4707, ou par courrier électronique à support@westwoodbaby.com

Si l'un des aspects des instructions n'était pas clair, veuillez communiquer avec votre marchand ou avec Westwood pour de l'aide.













Westwood Design
635 N. Billy Mitchell Rd.,
Salt Lake City, UT 84116
Phone: 908-719-4707

www.westwoodbaby.com

Parts & Hardware Included / Pièces et matériel inclus







HEADBOARD / Tête de lit

LIST OF HARDWARE / Liste de quincaillerie					LIST OF PARTS / Liste des pièces			
No.	Description			Q'ty	No.	Description	Picture	Q'ty
A		Allen Bolt / Boulon Allen	Ø5/16" * 1-1/2"	2	1	Headboard / Tête de lit		1
B		Lock Washer / Rondelle	Ø5/16" * 1.5mm	2	2	Headboard Leg Left / Pied gauche de la tête de lit		1
C		Metal Washer / Rondelle métallique	Ø5/16" * 19 * 1.5mm	2	3	Headboard Leg Right / Pied droit de la tête de lit		1
D		Thread Bolt / Boulon entièrement fileté	Ø5/16" * 3-1/4"	4	4	Headboard Bottom Stretcher / Traverse inférieure de la tête de lit		1
E		Curved Washer / Rondelle incurvée	5/16"	4				
F		Hex Nut / Écrou hexagonal		4				
G		Wrench / Clé		1				

FOOTBOARD / Pied de lit

LIST OF HARDWARE / Liste de quincaillerie					LIST OF PARTS / Liste des pièces			
No.	Description			Q'ty	No.	Description	Picture	Q'ty
H		Wood Screw / Vis à bois	4*32mm	10	5	Footboard / Pied de lit		1
I		Allen Wrench / Clé Allen	M4	1	6	Slats With Hole / Lattes trouées		13

FULL / TWIN SIDE RAIL / Traverse latérale pour lit double / simple

LIST OF HARDWARE / Liste de quincaillerie					LIST OF PARTS / Liste des pièces			
No.	Description			Q'ty	No.	Description	Picture	Q'ty
J		Thread Bolt / Boulon entièrement fileté	Ø5/16" * 3-1/4"	8	7	Bed Rails Left / Traverse de lit gauche		1
K		Curved Washer / Rondelle incurvée	5/16"	8	8	Bed Rails Right / Traverse droite du lit		1
L		Hex Nut / Écrou hexagonal		8				
M		Wrench / Clé		1				

Required Parts & Hardware / Pièces et matériel requis

Step 1 / Étape 1

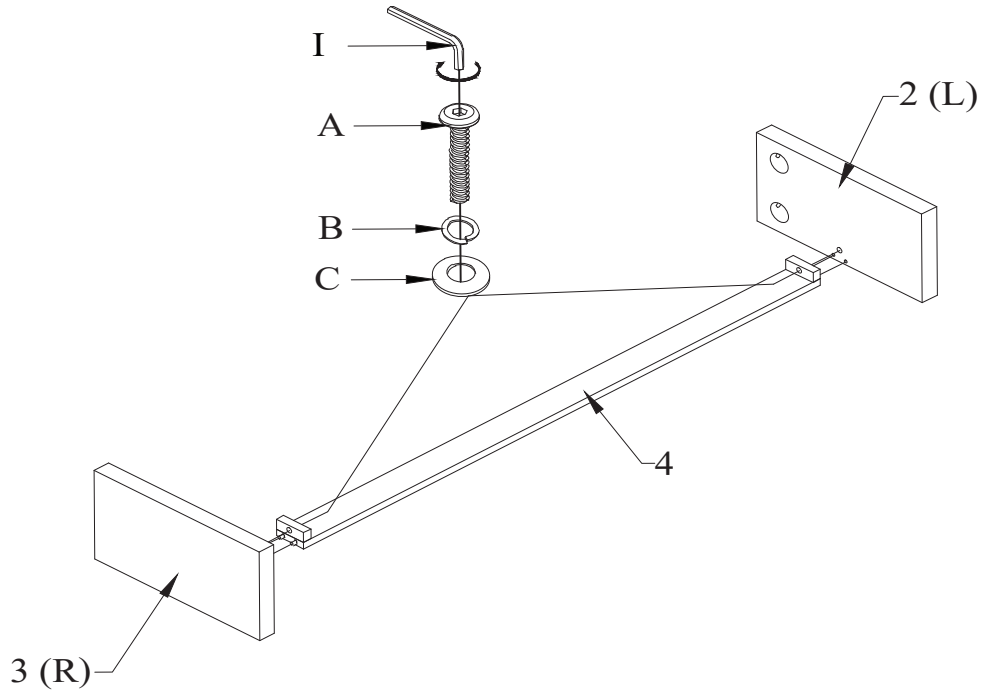

Step 2 / Étape 2

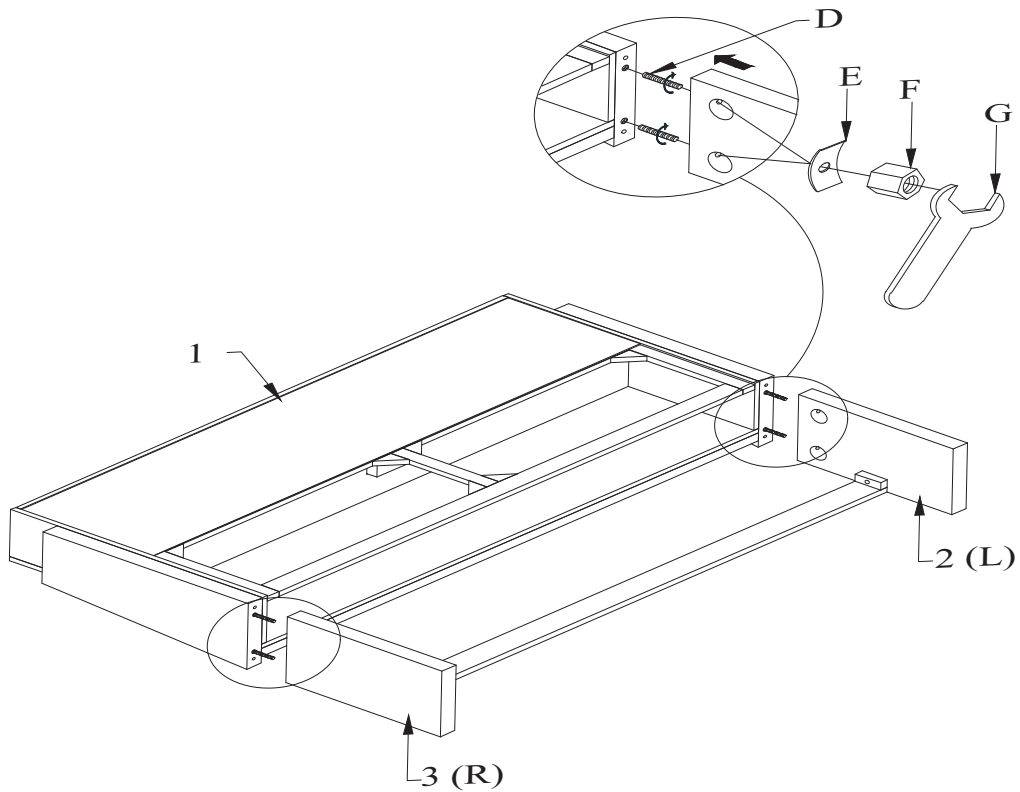

Required Parts & Hardware / Pièces et matériel requis

Step 3 / Étape 3

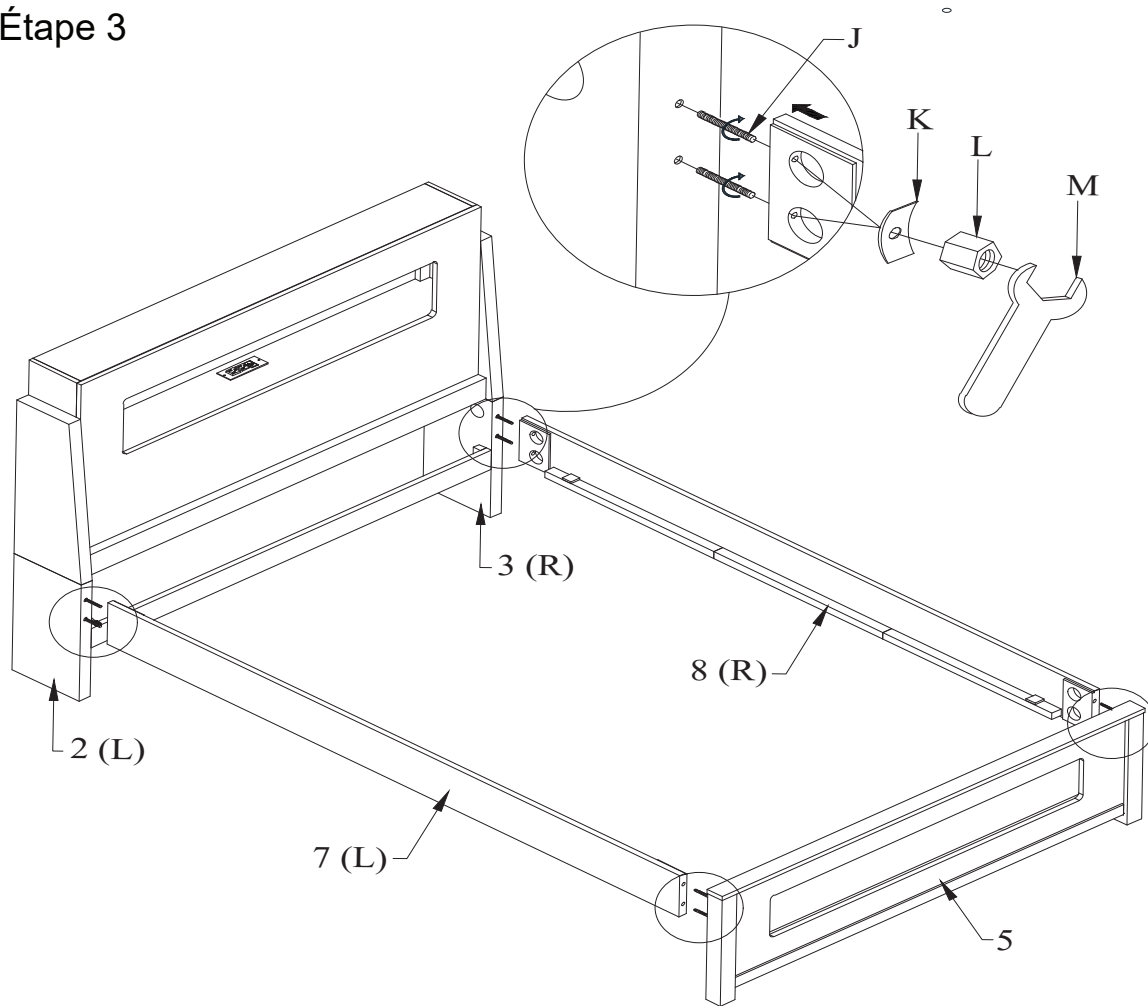

Step 4 / Étape 4

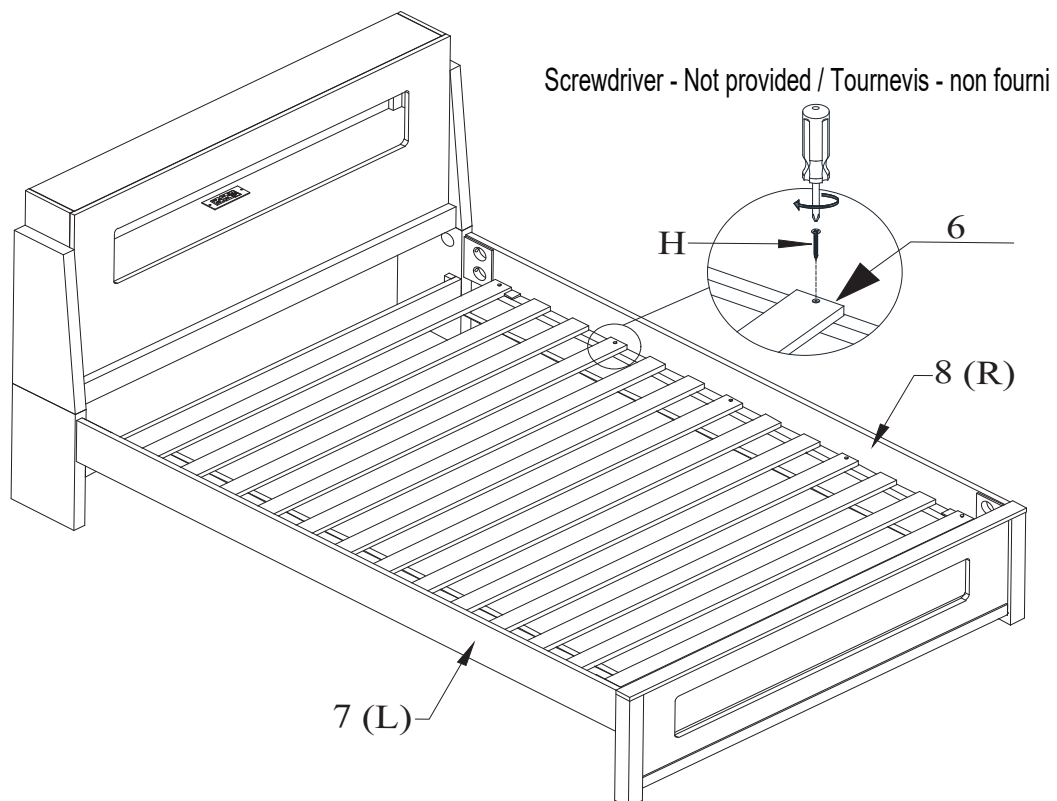

Required Parts & Hardware / Pièces et matériel requis

Step 5 / Étape 5

LED Light Connection /
Connexion de la lumière LED

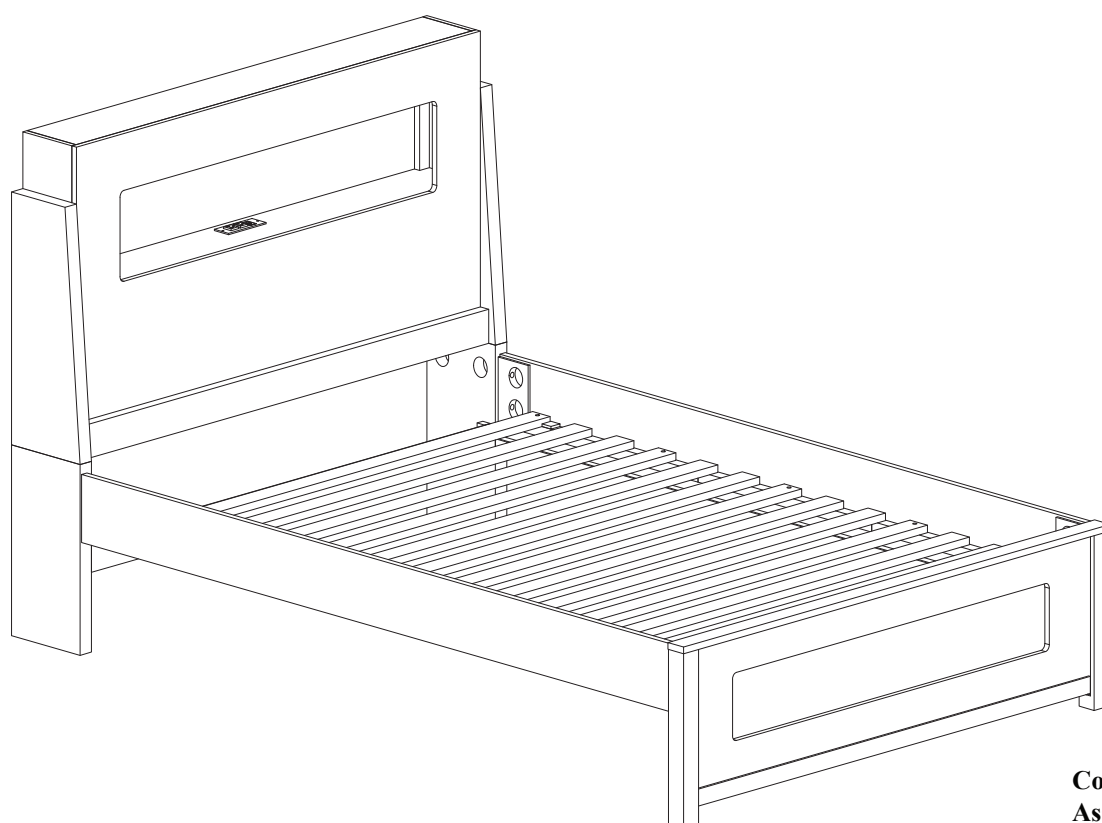
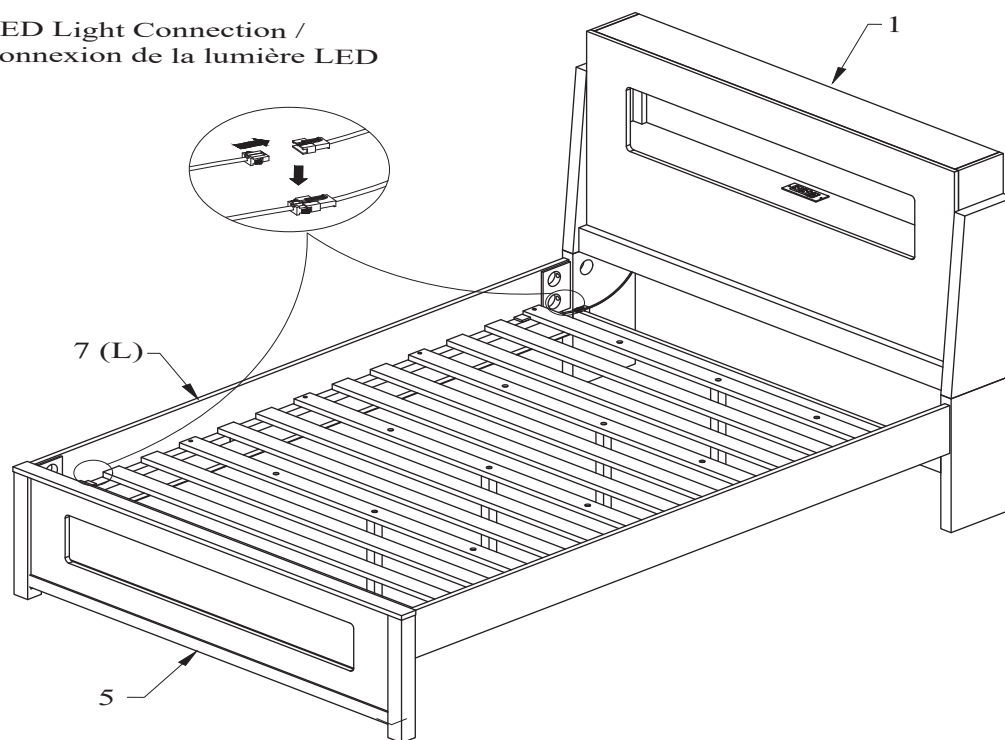

Complete Assembly
Assemblage complet

Made in Vietnam / Fabriqué au Vietnam