

Assembly Instructions Stratton Combo Hutch

- A.** Remove the hutch from the packaging, and use the Allen wrench to remove the three screws holding the protective board to the bottom of the hutch. You can discard this board.
- B.** If you are using a changing pad, secure it to the combo using the straps as instructed by the pad manufacturer. Center the hutch on top of the combo, then screw the wood screws (A) through the holes on the mounting plates and into the combo.
- C.** Insert the shelf tabs (B) into the desired holes, and carefully lower the shelves onto the tabs. Screw the wood screws through the holes in the bottom of the shelf tabs into the bottom of the shelf to prevent the shelf from being accidentally removed. If you are using the hutch with a changing pad, you should remove the lower shelf and save it for later use.
- D.** Plug the cord for the lights into a socket behind the combo. Do not run the wire in the open where children can access it. Turn on and dim the lights by touching the metal pad behind the right side edge.

A 2 x Wood Screw

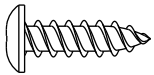

B 8 x Shelf Tab

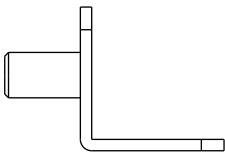

C Allen Wrench

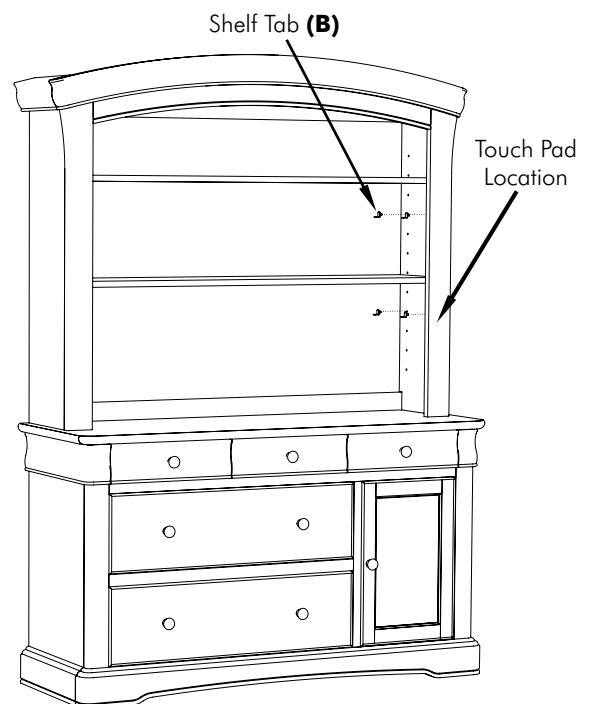
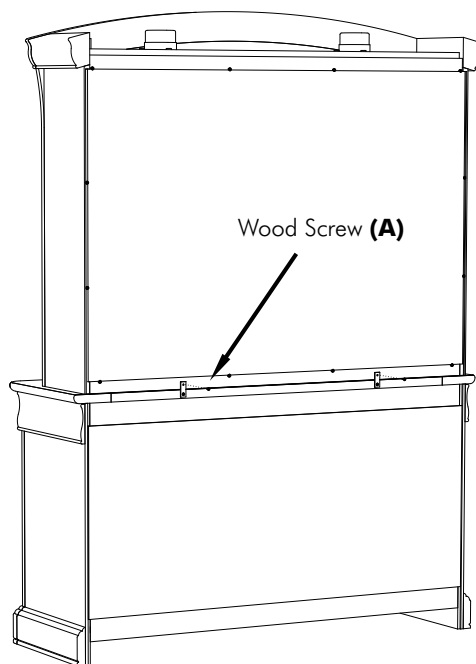
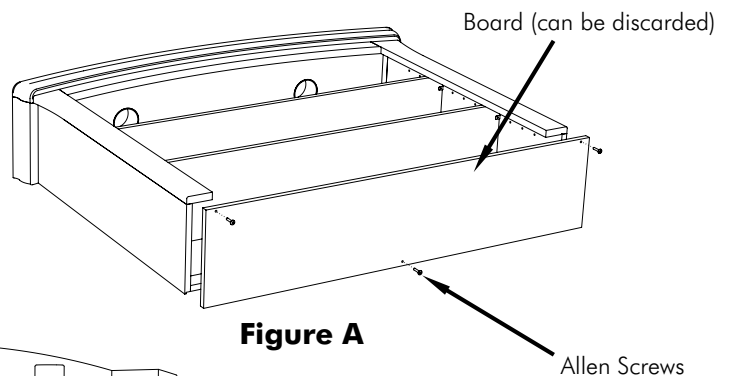
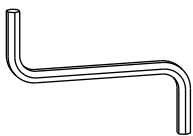

WESTWOOD DESIGN

635 N. Billy Mitchell Rd., Ste. B
Salt Lake City, UT 84116
Phone: 1-908-719-4707
support@westwoodbaby.com

October 24, 2007